

SCM15

FEATURES:

- (A) SPECIALLY DESIGNED WATER TIGHT FRAME & COVER ASSEMBLY CAST OF TOUGH DURABLE DUCTILE IRON. DETERS SURFACE WATERS WITHOUT THE USE OF GASKETS OR O-RINGS.
- (B) DUCTILE IRON CAST CONCRETE ANCHORS.
- (C) 14 GAUGE STAINLESS STEEL 15 GALLON CONTAINER.
- (D) FLEXIBLE, DOUBLE SEALING, VICTAULIC BUNA-N SEAL & FLANGE ASSEMBLY WITH STAINLESS STEEL BOLTS. ALLOWS FOR FROST HEAVING AND TILTING WITH GRADES.
- (E) HAND OPERATED ONE STROKE PUMP & HOSE ASSEMBLY MADE DURABLE PVC TRANSFER OF SPILLAGE INTO FILL PIPE.
- (F) STAINLESS STEEL SLUMP.

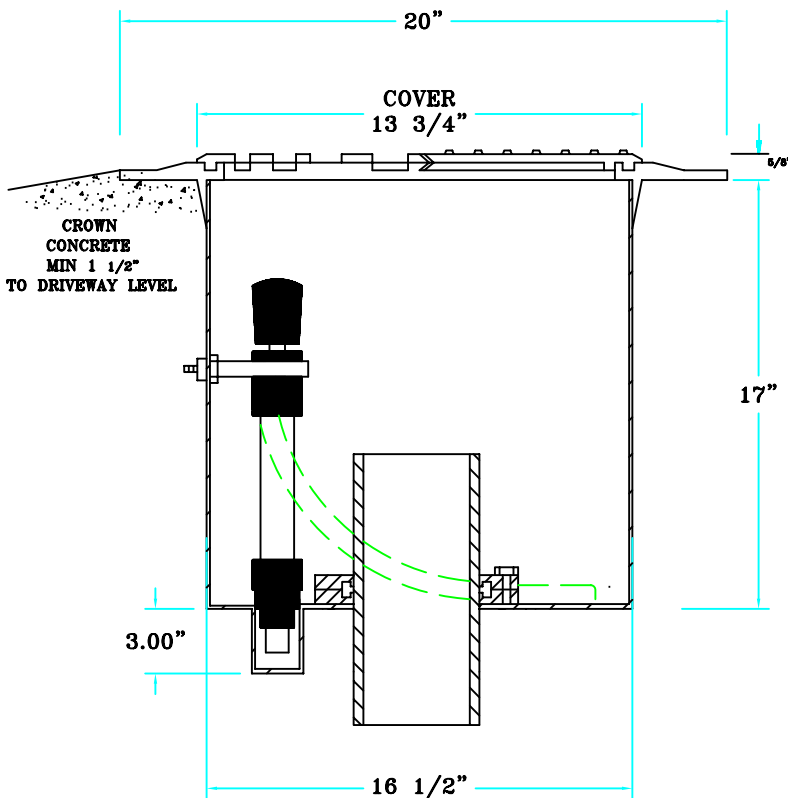

ADDITIONAL FEATURES

- SLIDE OVER FILL PIPES FOR QUICK AND EASY INSTALLATIONS.
- NO DEEP EXCAVATIONS.
- NO CUTTING OR THREADING TO FILL PIPES.
- DOES NOT INTERFERE WITH TANK INTEGRITY TESTS.
- RETROFITS ECONOMICALLY.
- NON-CORROSIVE CONSTRUCTION.
- LONG TERM, LITTLE MAINTENANCE.
- CAN BE INSTALLED ON REMOTE FILLS.

Model: SCM15

DWG: SCM15

Date: 10/01

SCM15

Note:

FAIRFIELD INDUSTRIES INC.

827 North 6th STREET NEWARK, NJ 07107
 PHONE 973-483-0100 FAX 973-483-5333